



Ramada Hotel Dover

The Perfect Solution for Meetings and Conferences

The Ramada Hotel Dover prides itself on catering for all your requirements and expectations with our flexible conference and banqueting packages.

When choosing this Hotel you can be sure that you will receive the highest standard of service and the best value for money without compromise.

The Ramada Hotel Dover offers a professional service, comfortable accommodation, excellent cuisine, attention to detail and a perfect ambience for conference and banqueting.

Our excellent meeting facilities are detailed in the enclosed pack and with the capacity to cater for up to 350 delegates, we are certain there will be a solution for you.

All our conference rooms are equipped with free WiFi, a conference convenience box, mints, conference pads and pens and jugs of iced water as standard. We also have a full range of conference equipment available to hire.

A wide selection of banqueting menus are available to suit all budgets or alternatively our Chef is more than happy for you to design your own menu which he will price individually.

Whilst this pack will provide you with all the necessary information to assist in the organization of your Conference or Banquet, we recommend that you contact a member of our Events Team to discuss your individual requirements and to arrange a visit to the Hotel.

We look forward to welcoming you to the Ramada Hotel Dover.

Regards,

Pat Milligan
Food & Beverage Manager
01304 872843 or email fandb@ramadadover.co.uk



RAMADA®

DOVER

The Grand Marquee



Ideal for larger Meetings, Conferences, Exhibitions



- ✓ Accommodates up to 400 delegates
- ✓ Easy Access to and from hotel
- ✓ Private Bar
- ✓ Internal heating system
- ✓ Integrated PA/Sound Ceiling
- ✓ Natural Day Light
- ✓ Floor Area: 400m²

Accommodates up to:

Theatre Style: 400 people
Banquet with Disco: 250 people
Banquet only: 290 people

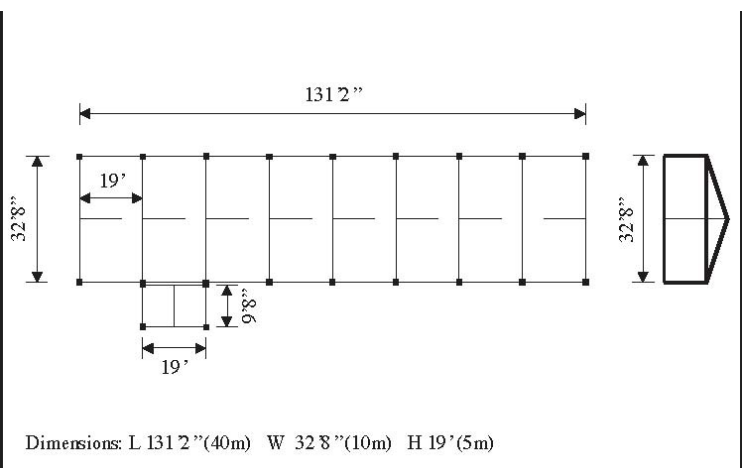



RAMADA®

DOVER

The Channel Suite

CONFERENCE SPACE

Make your Meeting a successful one in our lovely Channel Suite.



- ✓ **Ground Floor**
- ✓ **Easy Access to and from Hotel Reception**
- ✓ **Air-conditioned**
- ✓ **Direct access to the Restaurant**
- ✓ **Natural Day Light**
- ✓ **Floor Area: 56 m²**
- ✓ **Free Wifi**
- ✓ **Accommodates 60 people**

Accommodates up to:

Theatre Style: 60 people
U- Shape: 24 people
Boardroom: 22 people
Classroom: 25 people
Banquet: 48 people

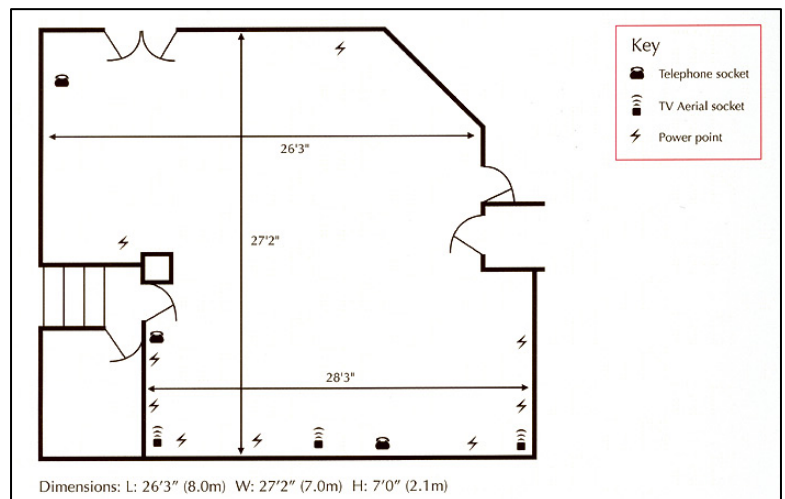



RAMADA[®]

DOVER

The Harbour Suite

For a small Meeting, Celebration or Occasion, the Harbour Suite is the best choice.



- ✓ **Ground Floor**
- ✓ **Air-conditioned**
- ✓ **Accommodates 30 people**
- ✓ **Natural Day Light**
- ✓ **Free WiFi**
- ✓ **Floor Area: 44 m²**

Accommodates up to:

Theatre Style: 30 people
U- Shape: 14 people
Boardroom: 16 people
Banquet: 24 people

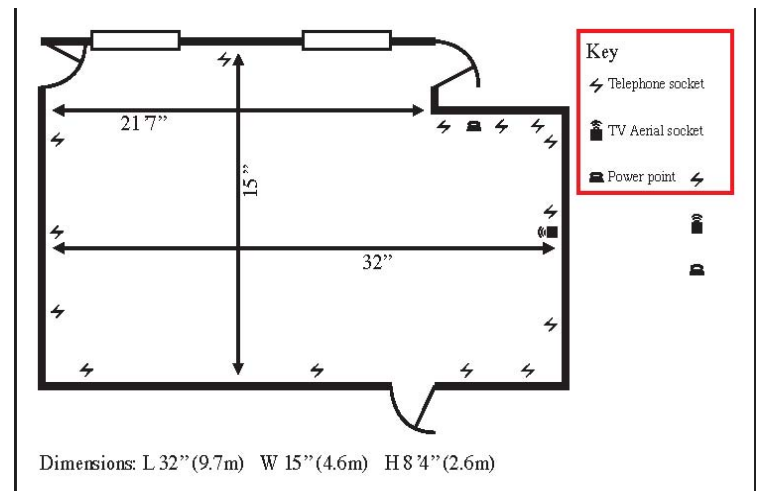



RAMADA®

DOVER

Bleriot's Restaurant



- ✓ Guests Numbers: 40 – 100 guests
- ✓ International Cuisine
- ✓ With Disco/Band: up to 72 guests
- ✓ Dance Floor – Free of Charge
- ✓ Ground Floor
- ✓ Air-conditioned
- ✓ Natural Day Light
- ✓ Piped Music
- ✓ Free wifi



The Ramada Hotel Dover does not allow any beverages or food to be brought into the premises.



The Bar Europa

Often used for informal meetings, Gatherings, Receptions and special Occasions.

- ✓ Ground Floor
- ✓ Air-conditioned
- ✓ Floor Area: 92 m²
- ✓ Natural Day Light
- ✓ Free WiFi



Accommodates up to:

Boardroom Style:	16 People
U- Shape:	25 People
Receptions:	75-100 People





RAMADA
DOVER

Conference Delegate Rates

Day Delegate Rate £30.00 per person

Rate includes the following:

Conference Room Hire
Conference Convenience Box
Conference Pads & Pens
Mints
Equipment Hire (excluding LCD Projector)
Iced Water

Tea, Coffee and Danish Pastries on arrival
Mid-morning Tea, Coffee and Cookies
2 Course Conference Buffet Lunch
Mid-afternoon Tea, Coffee and Cookies

24 Hour Delegate Rate £99.00 per person

Rate includes the following:

Conference Room Hire
Conference Convenience Box
Conference Pads & Pens
Mints
Equipment Hire (excluding LCD Projector)
Iced Water

Tea, Coffee and Danish Pastries on arrival
Mid-morning Tea, Coffee and Cookies
2 Course Conference Buffet Lunch
Mid-afternoon Tea, Coffee and Cookies
3 Course Evening Meal in our Bleriots Restaurant
Sole use accommodation in en-suite double room.
Ramada Buffet Breakfast

Day Delegate and 24 Hour Delegate Rates: Minimum numbers 10 (unless specified)



RAMADA®

DOVER

Room Name	Room Hire Rates <i>Full Day- 8.30am – 5.30pm</i> <i>Part Day- up to 4.5 hours</i> <i>Evening – After 6pm</i>	Capacity
Grand Marquee	Full Day - £600.00 Part Day - £300.00 Evening - £300.00	Theatre Style - 400 Banquet Style - With Disco - 250 Without Disco - 290
Channel Suite	Full Day - £140.00 Part Day - £90.00 Evening - £70.00	Theatre Style - 60 U-Shape - 24 Boardroom - 22 Classroom - 25 Banquet - 48
Harbour Suite	Full Day - £140.00 Part Day - £90.00 Evening - £70.00	Theatre Style - 30 U-Shape - 14 Boardroom - 16 Classroom - 15 Banquet - 24
Bleriots Restaurant	Full Day /Evening - £300.00 Part Day - £150.00	Banquet With Disco - 72 Without Disco - 100 Theatre Style - 150
Bar Europa	Full Day - £99.00 Part Day - £65.00	Boardroom - 16 U-Shape - 25 Receptions - 75-100
Syndicate Rooms	Available on request @ £70.00 per day/part thereof.	4 pax maximum



RAMADA
DOVER

Equipment Rates - Hire Only:

LCD Projector	-	£25.00
Large TV and VCR/ DVD	-	£50.00
Laptop Computer	-	£50.00
OHP	-	£25.00
Flipchart	-	£ 7.50
Screen	-	£ 5.00
Photocopying per sheet	-	£ 0 .10

Conference Refreshments Charges:

Tea Coffee only	-	£1.95 per person per serving
Tea, Coffee & Cookies/pastries	-	£2.25 per person per serving
Bottled Water – Still & Sparkling	-	Large £2.95 / Small £1.95 per Bottle
Orange Juice	-	£7.50 per Jug
Apple Juice	-	£7.50 per Jug
Crisps & Nuts	-	£2.20 per portion

The Hotel has a wide variety of menus and is able to cater for all dietary requirements, please advise and a menu will be provided specifically for you.

For more information please call 01304 872843 or email fandb@ramadadover.co.uk.



RAMADA®

DOVER

Conference Menus

Menu 1

Choose 4 Items from :

Cheddar Puffs
Sausage Rolls
Chicken Goujons
Assorted Quiche
Wings of Fire
Vegetable Samosa
Onion Bhajis
Chicken Tikka
Cocktail Sausages
Mini Pizzas

Choose 2 Items from :

Assorted Sandwiches
Assorted Vol Au Vents
Crisps & Peanuts
Mixed Salads
Assorted Canapes

£8.95 per person

Menu 3

Choose 4 Items from :

Cheddar Puffs
Sausage Rolls
Chicken Satay
Garlic Bread with Cheese
Wings of Fire
Vegetable Samosas
Onion Bhajis
Thai Fish Cakes
Cocktail Sausages
Salmon Goujons

Choose 3 Items from :

Assorted Sandwiches
Crudites
Assorted Vol Au Vents
Crisps & Peanuts
Mixed Salads
Nachos & Salsa

Dessert – Choose any 2 Items from :

Chocolate Gateaux
Lemon Meringue Pie
Strawberry Gateaux
Fresh Fruit Salad
Cheesecake

£12.95 per person

Menu 2

Choose 5 Items from :

Cheese & Onion Lattice
Sausage Rolls
Chicken Satay
Breaded Salmon Goujons
Spicy Potato Wedges
Vegetable Spring Rolls
Onion Bhajis
Masala Fried Chicken
Breaded Mushrooms
Mini Pizzas

Choose 3 Items from :

Assorted Sandwiches
Assorted Vol Au Vents
Crisps & Peanuts
Mixed Salads
Cheese & Pineapple Sticks

£10.00 per person

Menu 4

Choose any 1 from :

Char Grilled Chicken Supreme, Mushroom Sauce served with Rice and Steamed Vegetables

Battered Haddock Fillet served with Chips or New Potatoes and Vegetables

Chicken Tikka Masala served with Rice, Salad and Pappadoms

Stir Fried Beef Thai Style served with Rice and Spring Rolls

Grilled Gammon with Pineapple, Buttered Peas & Fries

Penne Neapolitan served with Garlic Bread

Vegetable Stroganoff served with Rice

Vegetable Au Gratin served with Crispy Salad and Garlic Bread.

Dessert - Choose any 1 from:

**Fresh Fruit Salad with Cream
Mandarin Cheesecake
Triple Layer Chocolate Gateaux
Bramley Apple Pie with Custard.**

£12.95 per person.



RAMADA®
DOVER

Menu 5

Choose any 1 from :

Starters

Prawn and Melon Cocktail

Served with dill cream & mayonnaise dressing and water cress

Home Made Vegetarian Soup

Served with a crusty bread roll

Ardennes Pate

Served with olive bread and red onion marmalade

Main Course

Grilled Supreme of Chicken

Served with a peppercorn sauce, buttered new potatoes & vegetables

Oven Roasted Salmon Fillet

Served with sauté greens and parsley potatoes

Braised Rump Steak

Served with root vegetables & herbed potatoes

Dessert - Choose any 1 from:

Fresh Fruit Salad with Cream

Black Forest Gateaux

Served with brandy cream & strawberry compote

Selection of Ice Cream & Sorbets

£14.95 per person